

Philips MasterColor® Elite Ceramic Metal Halide 70 Watt 3000K Tubular Single-Ended T6 Lamp

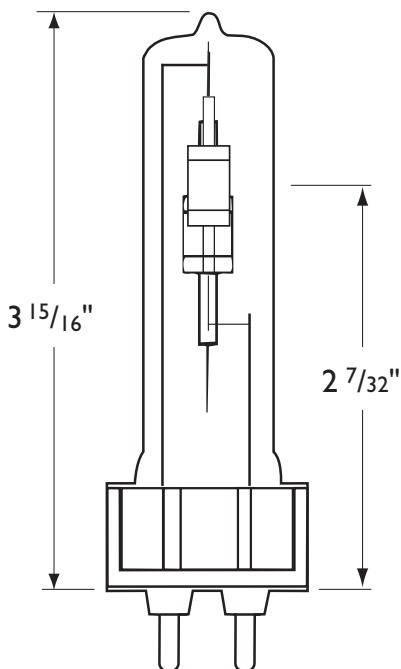

Ordering Information

Ordering Code	CDMElite70/T6/930
ANSI Designation	C139/E
Product Number	14836-1
Description	MasterColor Elite Ceramic Metal Halide
Package Qty.	12

Physical Characteristics

Bulb Size	T-6
Bulb Finish	Clear
Base	G-12 Bi-Pin
Max. Overall Length (MOL)	3 15/16" (100 mm)
Light Center Length (LCL)	2 7/32" (56 mm)
Arc Length	0.23" (5.75 mm)
Arc Tube Material	Polycrystalline Alumina
Max. Permissible Bulb Temp.	500° C (932° F)
Max. Permissible Base Temp.	250° C (482° F)
Max. Bulb to Base Eccentricity	3°
Max. Arc Tube to Base Eccentricity	3°

Operating Characteristics (Photometric)

Rated Initial Lumens ¹	7300
Mean Lumens, Approx. ²	6500
Rated Average Life, Hours ³	12,000
Correlated Color Temp. (CCT) ²	3000K
CIE Chromaticity, Approx. ²	x-.434, y-.395
Color Rendering Index (CRI)	90
Efficacy (lpw)	104

Operating Position

Universal-Enclosed Luminaires Only

Note: Use on thermally protected electronic ballast only.

PHILIPS

Philips MasterColor® Elite Ceramic Metal Halide 70 Watt 3000K Tubular Single-Ended T6 Lamp

Electrical Data (Subject to change without notice)

Lamp Watts (Nominal)	70
Lamp Operating Voltage (rms) (Nominal) ¹	86
Initial Lamp Voltage Range (rms) ⁵	80–100
Lamp Operating Current (Amps) (rms) (Nominal)	0.98
Lamp Current Crest Factor (Maximum)	1.8
Warm-up Time to 80% of Output	2 Minutes
Re-strike Time for Hot Lamp	4–8 Minutes
Ballast Type	ANSI C139
Ballast Open Circuit Voltage (Minimum).	198
Pulse Peak Volts	3000 Min., 4000 Max.
Pulse Width @ 90% Peak	2 Micro Second Min.
Pulse Repetition Rate (Minimum) ⁶	2 per Half Cycle
Minimum Operating Temperature	-30°C

- 1) Measured at 100 hrs. life. Approximate lumen values listed are for vertical operation of the lamp.
- 2) Approximate lumen output at 40% of lamp rated average life.
- 3) Rated average life is obtained, on the average, from large representative groups of lamps in laboratory tests under controlled conditions at 10 or more operating hours per start. It is based on survival of at least 50% of the lamps and allows for individual lamps or groups of lamps to vary considerably from the average.
- 4) Measured at rated lamp watts on a linear reactor. LPW does not include ballast losses.
- 5) Measured with the lamp operating at rated watts.
- 6) Option-Pulse Width @ 90% Peak, 1 micro second minimum with 2 pulses per half cycle.

Installation Information: MasterColor® Metal Halide T-6 lamps must be used in combination with appropriate ballast and ignitor or suitable full electronic ballast. For satisfactory operation of the lamp, the supply voltage should not fluctuate more than $\pm 5\%$ from the rated voltage of the ballast ($\pm 10\%$ for electronic ballast).

WARNINGS, CAUTIONS AND OPERATING INSTRUCTIONS

R **“WARNING:** These lamps can cause serious skin burn and eye inflammation from short wave ultraviolet radiation if outer envelope of the lamp is broken or punctured. Do not use where people will remain for more than a few minutes unless adequate shielding or other safety precautions are used. Certain lamps that will automatically extinguish when the outer envelope is broken or punctured are commercially available.” This lamp complies with FDA radiation performance standard 21 CFR subchapter J. (USA:21 CFR 1040.30 Canada:SOR/DORS/80-381)

If the outer bulb is broken or punctured, turn off at once and replace the lamp to avoid possible injury from hazardous short wave ultraviolet radiation. Do not scratch the outer bulb or subject it to pressure as this could cause the outer bulb to crack or shatter. A partial vacuum in the outer bulb may cause glass to fly if the envelope is struck.

WARNING: The arc-tube of metal halide lamps are designed to operate under high pressure and at temperatures up to 1000° C and can unexpectedly rupture due to internal or external factors such as a ballast failure or misapplication. If the arc-tube ruptures for any reason, the outer bulb may break and pieces of extremely hot glass might be discharged into the surrounding environment. If such a rupture were to happen, **THERE IS A RISK OF PERSONAL INJURY, PROPERTY DAMAGE, BURNS AND FIRE.**

Certain lamps that will retain all the glass particles should inner arc-tube rupture occur are commercially available from Philips Lighting Company.

RELAMP FIXTURES AT OR BEFORE THE END OF RATED LIFE. Allowing lamps to operate until they fail is not advised and may increase the possibility of inner arc tube rupture.

This lamp contains an arc tube with a filling gas containing Kr-85 and is distributed by Philips Lighting Company, a division of Philips Electronics North America Corporation, Somerset, New Jersey, 08875.

CAUTION: TO REDUCE THE RISK OF PERSONAL INJURY, PROPERTY DAMAGE, BURNS AND FIRE RESULTING FROM AN ARC-TUBE RUPTURE THE FOLLOWING LAMP OPERATING INSTRUCTIONS MUST BE FOLLOWED:

LAMP OPERATING INSTRUCTIONS:

1. RELAMP FIXTURES AT OR BEFORE THE END OF RATED LIFE. Allowing lamps to operate until they fail is not advised and may increase the possibility of inner arc tube rupture.
2. Use only in fully enclosed fixtures capable of withstanding particles of glass having temperatures up to 1000° C. Lens/diffuser material must be heat resistant. Consult fixture manufacturer regarding the suitability of the fixture for this lamp.
3. Do not operate a fixture with a missing or broken lens/diffuser.
4. Operate lamp only within specified limits of operating position.
5. Before lamp installation/replacement, shut power off and allow lamp and fixture to cool to avoid electrical shock and potential burn hazards.
6. Use only auxiliary equipment meeting Philips and/or ANSI standards. Use within voltage limits recommended by ballast manufacturer.
 - A. Operate lamp only within specified limits of operation.**
 - B. For total supply load refer to ballast manufacturers electrical data.**
 - C. Operate CDM-T6 (G12 base) lamps only on thermally protected ballasts.**
 - D. Operate CDM-TC lamps (G8.5 base), CDM-T6 Elite lamps, and CDM-T6 39W/842 lamps only on thermally protected electronic ballasts.**
7. Periodically inspect the outer envelope. Replace any lamps that show scratches, cracks or damage.
8. If a lamp bulb support is used, be sure to insulate the support electrically to avoid possible decomposition of the bulb glass.
9. Protect lamp base, socket and wiring against moisture, corrosive atmospheres and excessive heat.
10. Time should be allowed for lamps to stabilize in color when turned on for the first time. This may require several hours of operation, with more than one start. Lamp color is also subject to change under conditions of excess vibration or shock and color appearance may vary between individual lamps.
 - I. Lamps may require 4 to 8 minutes to re-light if there is a power interruption.
 - II. Take care in handling and disposing of lamps. If an arc tube is broken, avoid skin contact with any of the contents or fragments.

