

# Ceramalux® High Pressure Sodium Non-Cycling 250 Watt ED-18 (Clear) Lamp

Featuring ALTO® Lamp Technology

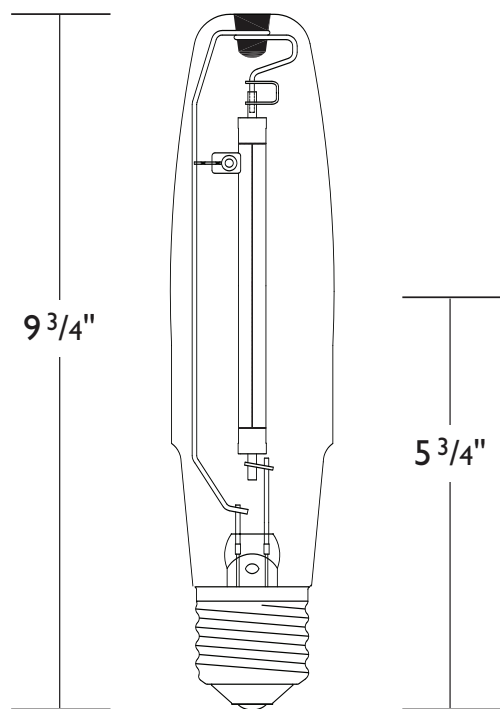

## w Ordering Information

Ordering Code	C250S50/ALTO NC HPS I2PK
ANSI Designation	S50
Product Number	14742-1
Description	High Pressure Sodium TCLP* Compliant Non-Cycling
Package Quantity	12

## w Physical Characteristics

Bulb Size	ED-18
Bulb Finish	Clear
Base	Mogul Screw
Maximum Overall Length (MOL)	9 3/4" (248mm)
Light Center Length (LCL)	5 3/4" (146mm)
Arc Length	2.4" (62mm)
Arc Tube Length	3.5" (91mm)
Arc Tube Material	Aluminum Oxide
Max. Permissible Bulb Temp.	400°C (752°F)
Max. Permissible Base Temp.	210°C (410°F)
Max. Bulb to Base Eccentricity	3°
Max. Arc Tube to Base Eccentricity	3°

## w Operating Characteristics (Photometric)

Approx. Initial Lumens <sup>1</sup>	28,500
Approx. Mean Lumens <sup>2</sup>	25,650
Rated Average Life, Hours <sup>4</sup>	30,000
Correlated Color Temperature (CCT) <sup>3,5</sup>	2000 K
CIE Chromaticity Approximate <sup>3</sup>	x-.530, y-.405
Color Rendering Index (CRI)	25
Efficacy (lpw)	114

## w Operating Position

Universal

## w TCLP\* Characteristics

Toxicity Characteristic Leaching Procedure (US EPA TCLP) Results

	Hg	Pb
EPA Limit (mg/l) max	0.200	5.00
C250S50/ALTO NC HPS	0.082	0.76
Mercury (mg/lamps) max	6.6	

# PHILIPS

## Ceralux® High Pressure Sodium Non-Cycling 250 Watt ED-18 (Clear) Lamp

TCLP Compliant

Lamp Watts (Nominal) . . . . .	250
Lamp Operating Voltage (rms) (Nominal) <sup>3</sup> . . . . .	100
Initial Lamp Voltage Range (rms) <sup>6</sup> . . . . .	90–110
Lamp Operating Current (Amps) (rms) (Nominal) . . . . .	2.8
Maximum Lamp Starting Current (Amps) (rms) . . . . .	4.5
Lamp Current Crest Factor (Maximum) . . . . .	1.8
Warm-up Time to 80% of Output . . . . .	4 Minutes
Restrike Time for Hot Lamp . . . . .	1–2 Minutes
Ballast Type . . . . .	ANSI S50
Ballast Open Circuit Voltage (Minimum) . . . . .	198
Pulse Peak Volts . . . . .	2500 Min., 4000 Max.
Pulse Width @ 90% Peak . . . . .	1 Micro Second Minimum
Pulse Frequency (Minimum)	
Lag Ballast . . . . .	1 per Cycle
Lead Circuit Ballast . . . . .	1 per Half Cycle
Minimum Operating Temperature . . . . .	-30°C
Reference Ballast Impedance . . . . .	59 Ohms at 220V RIV
Maximum Lamp Watts . . . . .	315
Minimum Lamp Watts . . . . .	185
Maximum Voltage Increase by Fixture . . . . .	10

Approximate Lumen Maintenance Curve  
for ALTO NC HPS Lamps:

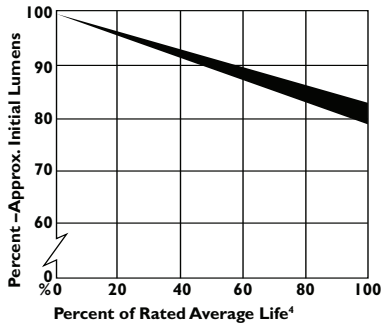

Approximate Survival Curve  
for ALTO NC HPS Lamps:

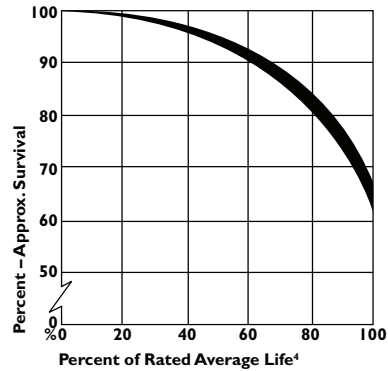

**Footnotes:**

- 1) Measured at 100 hrs. life. Approximate lumen values listed are for vertical or horizontal operation of lamp.
  - 2) Approximate mean lumen output at 40% of lamp rated average life.
  - 3) Measured at rated lamp watts on a linear reactor. LPV does not include ballast losses.
  - 4) Rated average life is the life obtained, on the average, from large representative groups of lamps in laboratory tests under controlled conditions at 10 or more operating hours per start. It is based on survival of 65% of the lamps and allows for individual lamps or groups of lamps to vary considerably from the average.
  - 5) Approximate color temperature in Kelvin degrees.
  - 6) Measured with the lamp operating at rated watts. Measured lamp voltage will change as the ballast changes lamp wattage.
- \*The TCLP is the US EPA's Toxicity Characteristic Leaching Procedure

**WARNINGS, CAUTIONS AND OPERATING INSTRUCTIONS for Ceralux High Pressure Sodium Lamps**

**R**“WARNING: These lamps must be operated in fixtures designed for use with High Pressure Sodium lamps. The fixture wattage rating must match the wattage indicated on the outer glass bulb. Do not scratch the outer bulb or subject it to pressure as this could cause the outer bulb to crack or shatter. A partial vacuum in the outer bulb may cause glass to fly if the glass is struck. Operating the lamp improperly may result in **PERSONAL INJURY, PROPERTY DAMAGE, BURNS AND FIRE.**

- 1) If the outer glass bulb is broken, shut off power immediately and remove the lamp after it has cooled.
- 2) Use only auxiliary equipment meeting Philips and/or ANSI standards. Use within voltage limits recommended by ballast manufacturer:
  - A. Operate lamp only within specified limits of operation.
  - B. For total supply load refer to ballast manufacturers electrical data.
- 3) Protect lamp base, socket and wiring against moisture, corrosive atmospheres and excessive heat.
- 4) Replace the lamp if the outer glass bulb has been scratched, cracked or damaged in any way.
- 5) If a lamp bulb support is used, be sure to insulate the support electrically so as to avoid possible decomposition of the bulb glass.
- 6) Do not use this lamp in a fixture which redirects a substantial portion of the energy toward the arc tube and its immediate vicinity, as this may lead to very early lamp failure.
- 7) Take care in handling and disposing of lamps. If arc tube is broken, avoid skin contact with any of the contents or fragments.
- 8) The arc tube of this lamp contains sodium and mercury. Dispose of in accordance with federal, state and local requirements.

